



**General Aptitude (GA)**

**Q.1 – Q.5 Multiple Choice Question (MCQ), carry ONE mark each (for each wrong answer: – 1/3).**

<b>Q.1</b>	<p><b>Consider the following sentences:</b></p> <p>(i) After his surgery, Raja hardly could walk.  (ii) After his surgery, Raja could barely walk.  (iii) After his surgery, Raja barely could walk.  (iv) After his surgery, Raja could hardly walk.</p> <p><b>Which of the above sentences are grammatically CORRECT?</b></p>
(A)	(i) and (ii)
(B)	(i) and (iii)
(C)	(iii) and (iv)
(D)	(ii) and (iv)

<b>Q.2</b>	<p><b>Ms. X came out of a building through its front door to find her shadow due to the morning sun falling to her right side with the building to her back. From this, it can be inferred that building is facing _____</b></p>
(A)	North
(B)	East
(C)	West
(D)	South

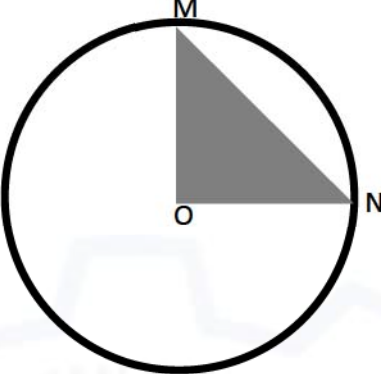

<p><b>Q.3</b></p>	<div style="text-align: center;">  </div> <p>In the above figure, O is the center of the circle and, M and N lie on the circle.</p> <p>The area of the right triangle MON is <math>50 \text{ cm}^2</math>.</p> <p>What is the area of the circle in <math>\text{cm}^2</math> ?</p>
<p>(A) <math>2\pi</math></p>	
<p>(B) <math>50\pi</math></p>	
<p>(C) <math>75\pi</math></p>	
<p>(D) <math>100\pi</math></p>	

<p><b>Q.4</b></p>	<p>If</p> $\begin{cases} \oplus \text{ means } "-", \\ \otimes \text{ means } "\div", \\ \Delta \text{ means } "+", \\ \nabla \text{ means } "\times", \end{cases}$ <p>then, the value of the expression <math>\Delta 2 \oplus 3 \Delta ((4 \otimes 2) \nabla 4) =</math></p>
<p>(A) -1</p>	
<p>(B) -0.5</p>	
<p>(C) 6</p>	
<p>(D) 7</p>	



Q.5	<p><b>“The increased consumption of leafy vegetables in the recent months is a clear indication that the people in the state have begun to lead a healthy lifestyle”</b></p> <p><b>Which of the following can be logically inferred from the information presented in the above statement?</b></p>
(A)	The people in the state did not consume leafy vegetables earlier.
(B)	Consumption of leafy vegetables may not be the only indicator of healthy lifestyle.
(C)	Leading a healthy lifestyle is related to a diet with leafy vegetables.
(D)	The people in the state have increased awareness of health hazards causing by consumption of junk foods.



Q. 6 – Q. 10 Multiple Choice Question (MCQ), carry TWO marks each (for each wrong answer: – 2/3).

Q.6	<p>Oxpeckers and rhinos manifest a symbiotic relationship in the wild. The oxpeckers warn the rhinos about approaching poachers, thus possibly saving the lives of the rhinos. Oxpeckers also feed on the parasitic ticks found on rhinos.</p> <p>In the symbiotic relationship described above, the primary benefits for oxpeckers and rhinos respectively are,</p>
(A)	Oxpeckers get a food source, rhinos have no benefit.
(B)	Oxpeckers save their habitat from poachers while the rhinos have no benefit.
(C)	Oxpeckers get a food source, rhinos may be saved from the poachers.
(D)	Oxpeckers save the lives of poachers, rhinos save their own lives.

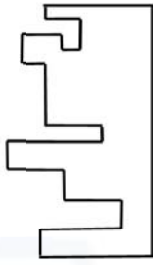
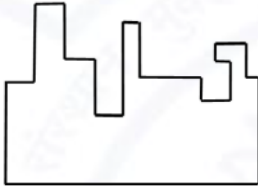
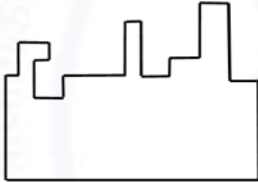
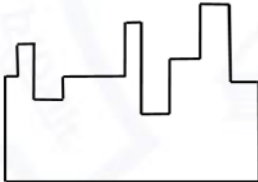
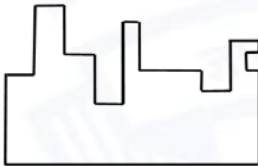

<p><b>Q.7</b></p>	<div style="text-align: center;">  </div> <p>A jigsaw puzzle has 2 pieces. One of the pieces is shown above. Which one of the given options for the missing piece when assembled will form a rectangle? The piece can be moved, rotated or flipped to assemble with the above piece.</p>
<p>(A)</p>	
<p>(B)</p>	
<p>(C)</p>	
<p>(D)</p>	



<b>Q.8</b>	<p>The number of hens, ducks and goats in farm P are 65, 91 and 169, respectively. The total number of hens, ducks and goats in a nearby farm Q is 416. The ratio of hens:ducks:goats in farm Q is 5:14:13. All the hens, ducks and goats are sent from farm Q to farm P.</p> <p>The new ratio of hens:ducks:goats in farm P is _____</p>
(A)	5:7:13
(B)	5:14:13
(C)	10:21:26
(D)	21:10:26

<b>Q.9</b>	<div style="display: flex; align-items: center;"> <table border="1" style="margin-left: 20px;"> <thead> <tr> <th>Company</th> <th>Ratio</th> </tr> </thead> <tbody> <tr> <td>C1</td> <td>3:2</td> </tr> <tr> <td>C2</td> <td>1:4</td> </tr> <tr> <td>C3</td> <td>5:3</td> </tr> <tr> <td>C4</td> <td>2:3</td> </tr> <tr> <td>C5</td> <td>9:1</td> </tr> <tr> <td>C6</td> <td>3:4</td> </tr> </tbody> </table> </div> <p>The distribution of employees at the rank of executives, across different companies C1, C2, ..., C6 is presented in the chart given above. The ratio of executives with a management degree to those without a management degree in each of these companies is provided in the table above. The total number of executives across all companies is 10,000.</p> <p>The total number of management degree holders among the executives in companies C2 and C5 together is _____.</p>	Company	Ratio	C1	3:2	C2	1:4	C3	5:3	C4	2:3	C5	9:1	C6	3:4
Company	Ratio														
C1	3:2														
C2	1:4														
C3	5:3														
C4	2:3														
C5	9:1														
C6	3:4														
(A)	225														
(B)	600														
(C)	1900														
(D)	2500														



<b>Q. 10</b>	<b>Five persons P, Q, R, S and T are sitting in a row not necessarily in the same order. Q and R are separated by one person, and S should not be seated adjacent to Q.</b> <b>The number of distinct seating arrangements possible is:</b>
(A)	4
(B)	8
(C)	10
(D)	16



**Reasoning and Comprehension (XH-B1)**

**Q.1 – Q.5 Multiple Choice Question (MCQ), carry ONE mark each (for each wrong answer: – 1/3).**

<p><b>Q.1</b></p>	<p>According to a recent article in a medical journal, consuming curcumin (from turmeric) significantly lowers the risk of COVID-19. The researchers draw this conclusion from a study that found that people who consumed one or more teaspoons of curcumin extract everyday were half as likely to be diagnosed with the disease as people who did not consume curcumin.</p> <p><b>Which of the following, if true, most weakens the argument in the article?</b></p>
<p>(A)</p>	<p>In another study, people who were given a zinc supplement everyday were more than four times less likely to be diagnosed with COVID-19 as those who did not.</p>
<p>(B)</p>	<p>All the participants in this study were from the same state where no other spices or herbs are consumed.</p>
<p>(C)</p>	<p>The participants who consumed curcumin were also more likely to exercise than those who did not.</p>
<p>(D)</p>	<p>In another study, COVID-19 patients who were given curcumin were no more likely to recover than others.</p>

<p><b>Q.2</b></p>	<p>Froot Inc. carried out an internet advertisement campaign for its new beverage CocoLoco. After the campaign, the director of the advertising company conducted a survey and found that the CocoLoco sales were higher than that of TenderJoos a competing product from Joos Inc. The agency concluded that the internet advertising campaign is more effective than advertising through other media.</p> <p><b>Which of the following statements could strengthen the conclusion above by the agency?</b></p>
<p>(A)</p>	<p>A ₹2 discount was offered on CocoLoco during the campaign period.</p>
<p>(B)</p>	<p>CocoLoco sales were higher than those of TenderJoos before the internet campaign.</p>
<p>(C)</p>	<p>A newspaper advertisement campaign the previous year did not increase CocoLoco sales.</p>
<p>(D)</p>	<p>During the campaign for CocoLoco, Joos Inc. did not advertise TenderJoos at all.</p>



<p><b>Q.3</b></p>	<p><b>An e-commerce site offered a deal last month conditional on the customer spending a minimum of ₹500. Any customer who buys 2 kg of fresh fruit will receive a hand mixer and any customer who buys 2 kg of fresh vegetables will receive a vegetable chopper.</b></p> <p><b>Which of the following is NOT a possible outcome of the above?</b></p>
<p>(A)</p>	<p>A customer purchased 3 kg of fresh fruit and did not receive a vegetable chopper.</p>
<p>(B)</p>	<p>A customer purchased items for ₹500 which included 1 kg of vegetables and received a hand mixer.</p>
<p>(C)</p>	<p>A customer purchased items for ₹500 which included 2 kg of vegetables and 1 kg of fruit and received a hand mixer.</p>
<p>(D)</p>	<p>A customer purchased items for ₹300 which included 2 kg of fruit and received neither a hand mixer nor a vegetable chopper.</p>

<p><b>Q.4</b></p>	<p><b>Writers of detective fiction often include an incompetent detective as a foil for the brilliant investigator-protagonist as they follow different paths in trying to solve the crime. In the individual accounts, the incompetent detective is frequently distracted by the culprit's careful plans, while the competent investigator solves the case after a final confrontation. Analysts of such fiction believe that the authors select this story-telling technique to provide readers with more complexities in the form of misleading clues, while figuring out the crime.</b></p> <p><b>Which of the following statements most logically follows from the passage above?</b></p>
<p>(A)</p>	<p>A detective story is considered well-written if the brilliant investigator is accompanied by an incompetent detective.</p>
<p>(B)</p>	<p>Writers of detective fiction use the contrast of an incompetent detective to mainly show how complex the investigation is.</p>
<p>(C)</p>	<p>Writers of detective fiction never write stories where the incompetent detective solves the case.</p>
<p>(D)</p>	<p>Writers of detective fiction use two investigative accounts to make it difficult for the reader to figure out the outcome.</p>



<p><b>Q.5</b></p>	<p><b>The first (P1) and the last (P6) parts of a single sentence are given to you. The rest of the sentence is divided into four parts and labelled (L,M,N,O). Reorder these parts so that the sentence can be read through correctly and select one of the options given.</b></p> <p><i>P1: Studies of several Sahitya Akademi award winners show that...</i></p> <p>L: or encounter professional</p> <p>M: and invariably develop a strained relationship with other literary figures</p> <p>N: they often publish very little</p> <p>O: after winning the prize</p> <p><i>P6: ...envy and rivalry.</i></p> <p><b>The correct order is:</b></p>
<p>(A)</p>	<p>NOLM</p>
<p>(B)</p>	<p>MLON</p>
<p>(C)</p>	<p>ONML</p>
<p>(D)</p>	<p>MOLN</p>



Q.6 – Q.10 Multiple Choice Question (MCQ), carry TWO mark each (for each wrong answer: – 2/3).

Q. 6	<p>Gerrymandering refers to the targeted redrawing of election constituencies so as to benefit a particular party. This is especially important where the electoral system is “first past the post” in each constituency (i.e. one winner is selected in each constituency based on a majority of votes won) and where there is no other provision for proportional representation (as for example in the German system). For a simple illustration of gerrymandering, if a region consists of districts 1, 2, 3, ..., 9 with districts 1, 2, 3, 4, 5, 6 favouring party P and 7, 8, 9 favouring party Q, then grouping of districts to constituencies as {1,2,3}, {4,5,6}, {7,8,9} will give two seats to party P and one seat to party Q, whereas the grouping {1,2,7}, {3,4,8}, {5,6,9} will give all three seats to party P, as they will secure a majority in each constituency.</p> <p>Which of these statements can be deduced from the above?</p>
(A)	Gerrymandering implies that constituency boundaries can sometimes be drawn to favour one party over the other.
(B)	Gerrymandering implies that proportional representation is impossible when districts are grouped to form constituencies.
(C)	To counteract gerrymandering political parties should concentrate on districts where they are favoured.
(D)	The grouping of districts to constituencies has very little impact on proportional representation.



<p><b>Q. 7</b></p>	<p><b>X-ray examination of a recently discovered painting that some authorities judge to be a self-portrait by Michelangelo revealed an under-image of a woman's face. Either Michelangelo or some other artist must have repainted over the first painting that had now been seen on the canvas. Because the woman's face also appears on other paintings by Michelangelo, this painting is determined to indeed be an authentic painting by Michelangelo.</b></p> <p><b>Which of the following assumptions must be made in reaching the conclusion above?</b></p>
<p>(A)</p>	<p>When an already painted canvas of an artist is used, the second artist using that canvas for a new painting is usually influenced by the artistic style of the first.</p>
<p>(B)</p>	<p>Several painted canvases that art historians attribute to Michelangelo contain under-images that appear on at least one other of Michelangelo's paintings.</p>
<p>(C)</p>	<p>Subject or subjects that appear in authenticated paintings of Michelangelo are rather unlikely to show up as under-images on painted canvases not attributed to Michelangelo.</p>
<p>(D)</p>	<p>No painted canvas can be attributed to a particular artist with certainty without an X-ray analysis.</p>

<p><b>Q. 8</b></p>	<p><b>This season _____ tourists visited Ladakh than last season; however, _____ to be the biggest tourist destination in India. The tourism department explains that the number of tourists to India has _____ relative to previous years, _____ have chosen to visit Ladakh.</b></p> <p><b>Select the correct sequence of phrases to fill in the blanks to complete the passage above.</b></p>
<p>(A)</p>	<p>more / for the first time in many seasons it does not appear / increased / and it seems that most</p>
<p>(B)</p>	<p>fewer / as in the past, it appears / in fact decreased / but it seems that only a small proportion</p>
<p>(C)</p>	<p>fewer / for the first time in many seasons it appears / in fact decreased / but it seems that most</p>
<p>(D)</p>	<p>more / this season as well, it appears / in fact decreased / but it seems that a large proportion</p>



<p><b>Q. 9</b></p>	<p>Reorder the sentences in (1) – (5) such that they form a coherent paragraph.</p> <p>(1) In fact, dozens of languages today have only one native speaker still living, and that person's death will mean the extinction of the language: It will no longer be spoken, or known, by anyone on earth.</p> <p>(2) Many languages are falling out of use and are being replaced by others that are more widely used in the region or nation, such as English in Australia or Portuguese in Brazil.</p> <p>(3) Many other languages are no longer being learned by new generations of children or by new adult speakers.</p> <p>(4) An endangered language is one that is likely to become extinct in the near future.</p> <p>(5) Unless the trends are reversed, these endangered languages will become extinct by the end of the century.</p> <p>(Adapted from <i>What is an Endangered Language</i> by A. Woodbury.)</p>
<p>(A)</p>	<p>2 3 1 4 5</p>
<p>(B)</p>	<p>2 3 5 4 1</p>
<p>(C)</p>	<p>4 1 5 2 3</p>
<p>(D)</p>	<p>4 2 3 1 5</p>



<p><b>Q. 10</b></p>	<p>The first (P1) and the last (P6) parts of a single sentence are given to you. The rest of the sentence is divided into four parts and labelled L,M,N,O. Reorder these parts so that the sentence can be read correctly and select one of the sequences below.</p> <p><i>P1: For a little while...</i></p> <p><b>L: it was a common belief</b></p> <p><b>M: right after the treaty of Versailles</b></p> <p><b>N: that Germany had caused World War I not just by her actions</b></p> <p><b>O: held by analysts and politicians alike</b></p> <p><i>P6: ... but by also encouraging Italy in her own aggressions.</i></p>
(A)	LMNO
(B)	MLON
(C)	LNMO
(D)	MOLN



**Q.11 – Q.15 Multiple Select Question (MSQ), carry TWO mark each (no negative marks).**

<p><b>Q. 11</b></p>	<p>After Florentino Ariza saw her for the first time, his mother knew before he told her because he lost his voice and his appetite and spent the entire night tossing and turning in his bed. But when he began to wait for the answer to his first letter, his anguish was complicated by diaorrhea and green vomit, he became disoriented and suffered from sudden fainting spells, and his mother was terrified because his condition did not resemble the turmoil of love so much as the devastation of cholera. Florentino Ariza’s godfather, an old homeopathic practitioner who had been Tránsito Ariza’s confidant ever since her days as a secret mistress, was also alarmed at first by the patient’s condition, because he had the weak pulse, the hoarse breathing, and the pale perspiration of a dying man. But his examination revealed that he had no fever, no pain anywhere, and that his only concrete feeling was an urgent desire to die. All that was needed was shrewd questioning, first of the patient and then of his mother, to conclude once again that the symptoms of love were the same as those of cholera. He prescribed infusions of linden blossoms to calm the nerves and suggested a change of air so he could find consolation in distance, but Florentino Ariza longed for just the opposite: to enjoy his martyrdom.</p> <p>(Adapted from <i>Love in a Time of Cholera</i> by Gabriel García Márquez.)</p> <p><b>The author of the passage is implying that:</b></p>
<p>(A)</p>	<p>Homeopathy cures love.</p>
<p>(B)</p>	<p>The doctor could not distinguish between love and cholera.</p>
<p>(C)</p>	<p>The doctor could distinguish between love and cholera.</p>
<p>(D)</p>	<p>The symptoms of love and cholera are similar.</p>



Q. 12	<p>Now, it is clear that the decline of a language must ultimately have political and economic causes: it is not due simply to the bad influence of this or that individual writer. But an effect can become a cause, reinforcing the original cause and producing the same effect in an intensified form, and so on indefinitely. A man may take to drink because he feels himself to be a failure, and then fail all the more completely because he drinks. It is rather the same thing that is happening to the English language. It becomes ugly and inaccurate because our thoughts are foolish, but the slovenliness of our language makes it easier for us to have foolish thoughts.</p> <p>(Adapted from <i>Politics and the English Language</i> by George Orwell.)</p> <p>The illustration of the man who takes to drink is used to underscore which of the following ideas in the passage above?</p>
(A)	Political and economic causes control deterioration of language.
(B)	Foolish thoughts are enabled by inaccurate language.
(C)	Effect of an action becomes the cause in a cyclic pattern.
(D)	Drinking enables people to have foolish thoughts and slovenly language.



<p><b>Q. 13</b></p>	<p>It is a pity that Caste even today has its defenders. The defences are many. It is defended on the grounds that the Caste System is but another name for division of labour, and if division of labour is a necessary feature of every civilised society, then it is argued that there is nothing wrong in the Caste System. Now the first thing to be urged against this view is that Caste System is not merely division of labour. It is also a division of labourers. Civilised society undoubtedly needs division of labour but nowhere is division of labour accompanied by this unnatural division of labourers into watertight compartments, grading them one above the other. This division of labour is not spontaneous or based on natural aptitudes. Social and individual efficiency requires us to develop the individual capacity and competency to choose and to make his own career. This principle is violated in so far as it involves an attempt to appoint tasks to individuals in advance, not on the basis of trained original capacities, but on that of birth. Industry undergoes rapid and abrupt changes and an individual must be free to change his occupation and adjust himself to changing circumstances, to gain his livelihood. (Adapted from <i>Annihilation of Caste</i> by Dr. B.R. Ambedkar.)</p> <p>Which of the following observations substantiate the arguments found in the passage above?</p>
<p>(A)</p>	<p>Newer generations are unable to change and move away from low-paying family professions, even with changed economic circumstances.</p>
<p>(B)</p>	<p>Sedentary desk jobs are considered to have more value and are in greater demand than those involving manual labour.</p>
<p>(C)</p>	<p>The government's jobs guarantee programme makes low-level management jobs available across all industries to all graduates in the nation.</p>
<p>(D)</p>	<p>A bus driver becomes an app creator and, in the course of one month, reaches one million downloads on Playstore with a four-star rating.</p>



Q. 14	<p>Imagine that you're in a game show and your host shows you three doors. Behind one of them is a shiny car and behind the others are goats. You pick one of the doors and get what lies within. After making your choice, your host chooses to open one of the other two doors, which inevitably reveals a goat. He then asks you if you want to stick with your original pick, or switch to the other remaining door. What do you do? Most people think that it doesn't make a difference and they tend to stick with their first pick. With two doors left, you should have a 50% chance of selecting the one with the car. If you agree, then you have just fallen afoul of one of the most infamous mathematical problems – the Monty Hall Problem. In reality, you should switch every time which doubles your odds of getting the car. Over the years, the problem has ensnared countless people, but not, it seems, pigeons. The humble pigeon can learn with practice the best tactic for the Monty Hall Problem, switching from their initial choice almost every time. Amazingly, humans do not!</p> <p>(Adapted from an article by Ed Yong in <i>Discover Magazine</i>.)</p> <p>Which of the following conclusions follow from the passage above?</p>
(A)	Humans calculate the probability of independent, random events such as the opening of a door by dividing the specific outcomes by the total number of possible outcomes.
(B)	Humans find it very difficult to learn to account for the host's hand in making the event non-random and, thereby, changing the outcome of the event.
(C)	Calculating probabilities is difficult for humans but easy for pigeons; which is why the pigeons succeed where the humans fail.
(D)	Humans are governed by reason, but pigeons are irrational and only interested in the outcome and will do whatever it takes to get food.



Q. 15	<p>The truth is that, despite the recent success of car-makers P and Q, India's automobile industry is in a state not that different from the bad old days of the license-permit quota raj when two carmakers dominated a captive domestic market with substandard vehicles and with very little, if any, research and development, and low to negligible productivity growth. High tariff barriers have certainly induced foreign automobile makers to enter the Indian market by setting up local operations, but this so-called "tariff jumping" foreign investment has produced an industry that is inefficient, operating generally at a low scale, and whose products are not globally competitive either in terms of cost or of innovation. It is noteworthy that the automobile parts industry, which has faced low tariffs (as low as 12.5%) and has been largely deregulated, has been characterised by higher productivity and much better export performance than the completely-built units' sector in the years since liberalisation.</p> <p>(Adapted from an Op-Ed in <i>The Mint</i>.)</p> <p>Which of the following statements can be inferred from the above?</p>
(A)	Low tariff barriers increase productivity.
(B)	Tariff jumping leads to increases in productivity.
(C)	Deregulation has worked for the automotive parts industry and therefore should be applied to completely-built units.
(D)	P and Q do not invest enough in research and development.



**English (XH-C2)**

**Q.1 – Q.12 Multiple Choice Question (MCQ), carry ONE mark each (for each wrong answer: – 1/3).**

<b>Q.1</b>	<b>Which of the following texts is a collection of stories that a group of pilgrims tell each other?</b>
(A)	<i>The Shepheardes Calender</i>
(B)	<i>The Pilgrim's Progress</i>
(C)	<i>The Canterbury Tales</i>
(D)	<i>Parliament of Fowls</i>

<b>Q.2</b>	<b>Which of these is NOT an autobiography?</b>
(A)	Baby Kamble, <i>The Prisons We Broke</i>
(B)	Bama, <i>Karukku</i>
(C)	Mulk Raj Anand, <i>Untouchable</i>
(D)	Om Prakash Valmiki, <i>Joothan</i>

<b>Q.3</b>	<b>Writers Workshop and Bhaft are _____.</b>
(A)	niche publishing houses in India that focus on particular genres
(B)	little magazines that were set up by small collectives of writers
(C)	digital archives of performance poetry
(D)	well-known reading circles in 1950s' Lucknow



<p><b>Q.4</b></p>	<p>The following lines capture the central trope of a well-known 18<sup>th</sup> century satirical tract.</p> <p>“I have been assured by a very knowing American of my acquaintance in London, that a young healthy child, well nursed, is, at a year old, a most delicious, nourishing, and wholesome food...”</p> <p>Identify the tract from the options below.</p>
<p>(A)</p>	<p>John Stuart Mill, “On Liberty”</p>
<p>(B)</p>	<p>Francis Bacon, “On Death”</p>
<p>(C)</p>	<p>Jonathan Swift, “A Modest Proposal”</p>
<p>(D)</p>	<p>Robert Graves, “Warning to Children”</p>

<p><b>Q.5</b></p>	<p>Whose poem does Cleanth Brooks close-read to arrive at his concept of “the well-wrought urn”?</p>
<p>(A)</p>	<p>William Wordsworth</p>
<p>(B)</p>	<p>John Keats</p>
<p>(C)</p>	<p>William Blake</p>
<p>(D)</p>	<p>Alfred Tennyson</p>

<p><b>Q.6</b></p>	<p>What is common among Charles Dickens’ <i>A Tale of Two Cities</i>, Mahasweta Devi’s <i>Mother of 1084</i>, Shobha Shakti’s <i>Gorilla</i>, and Chimamanda Ngozi Adichie’s <i>Half of A Yellow Sun</i>?</p>
<p>(A)</p>	<p>These novels are set during times of political uprisings.</p>
<p>(B)</p>	<p>These novels are feminist narratives.</p>
<p>(C)</p>	<p>These novels have animals as central characters.</p>
<p>(D)</p>	<p>These novels are picaresque novels.</p>



<b>Q.7</b>	<b>Henry James’ essay “The Art of Fiction”, one of the earliest literary critical engagements with the form of the novel, was preceded by his book-length study of _____.</b>
(A)	William Faulkner
(B)	Nathaniel Hawthorne
(C)	Aphra Behn
(D)	Oscar Wilde

<b>Q.8</b>	<b>Which of the following is NOT true of Bram Stoker’s <i>Dracula</i>?</b>
(A)	It is considered to be a gothic novel.
(B)	It is narrated mostly through letters.
(C)	Transylvania is an important setting in the novel.
(D)	It is a bildungsroman.

<b>Q.9</b>	<p><b>“The name is H. Hatterr, and I am continuing . . . Biologically, I am fifty-five of the species.”</b></p> <p><b>The lines above are from an early Indian English novel. Who is the author of this novel?</b></p>
(A)	G. V. Desani
(B)	Allan Sealy
(C)	Toru Dutt
(D)	Ruth Praver Jhabvala



<b>Q.10</b>	<b>In <i>Areopagitica</i>, John Milton made an impassioned appeal _____.</b>
(A)	against censorship and for freedom of expression
(B)	for legal reform allowing divorce based on spousal incompatibility
(C)	for freedom of the church from royal control
(D)	against slavery in the New World

<b>Q.11</b>	<b>The first institution to teach English Literature in the world is - _____.</b>
(A)	The University of Oxford, Oxford
(B)	Royal Polytechnic Institution, London
(C)	The College of William and Mary, Williamsburg, Virginia
(D)	Fort William College, Calcutta

<b>Q.12</b>	<b>Which one of the following texts propounds the aesthetic theory of 'rasa'?</b>
(A)	<i>Natya Shastra</i>
(B)	<i>Abhigyan Shakuntalam</i>
(C)	<i>Manu Smriti</i>
(D)	<i>Charaka Samhita</i>



Q.13 – Q.20 Multiple Select Question (MSQ), carry ONE mark each (no negative marks).

<b>Q.13</b>	<b>Which of the following novels is/are predominantly set in Bombay?</b>
(A)	Kiran Nagarkar, <i>Ravan and Eddie</i>
(B)	Rohinton Mistry, <i>A Fine Balance</i>
(C)	Salman Rushdie, <i>Midnight's Children</i>
(D)	Aravind Adiga, <i>The White Tiger</i>

<b>Q.14</b>	<b>Which of the following critically rewrite/s canonical English novels?</b>
(A)	J. M. Coetzee, <i>Foe</i>
(B)	Jean Rhys, <i>Wide Sargasso Sea</i>
(C)	Bapsi Sidhwa, <i>Ice-Candy-Man</i>
(D)	Ben Okri, <i>The Famished Road</i>

<b>Q.15</b>	<b>Of the following, which novelist/s combine/s feminist concerns with magic realism?</b>
(A)	Virginia Woolf
(B)	Toni Morrison
(C)	Kamala Markandaya
(D)	Svetlana Alexievich



<b>Q.16</b>	<b>In which of these Shakespearean plays do important female characters disguise themselves as men?</b>
(A)	<i>A Midsummer Night's Dream</i>
(B)	<i>The Merchant of Venice</i>
(C)	<i>As You Like It</i>
(D)	<i>Twelfth Night</i>

<b>Q.17</b>	<b>The following words in English are clustered according to their origin. Choose the cluster/s that contain/s words drawn from languages of the Indian subcontinent.</b>
(A)	Kedgerie, Punch, Mulligatawny, Candy
(B)	Shampoo, Chintz, Calico, Juggernaut
(C)	Philistine, Echo, Panic, Galaxy
(D)	Anaconda, Cheroot, Bungalow, Dungaree

<b>Q. 18</b>	<b>Which of the following is/are true of Charlotte Brontë's <i>Jane Eyre</i>?</b>
(A)	It was published under the pen-name Currer Bell.
(B)	It was published originally in three volumes.
(C)	It has been read as a critique of heterosexual romance, marriage, and domesticity.
(D)	The story is told from the point of view of a "madwoman in the attic".



<b>Q. 19</b>	<b>Which of the following is an example/are examples of noir, popular both as fiction and film?</b>
(A)	<i>The Big Sleep</i>
(B)	<i>Murder on the Orient Express</i>
(C)	<i>The Maltese Falcon</i>
(D)	<i>Fargo</i>

<b>Q. 20</b>	<b>Which of the following use/s the device of a 'story within a story' with multiple narrators?</b>
(A)	<i>A Portrait of an Artist as a Young Man</i>
(B)	<i>Wuthering Heights</i>
(C)	<i>Emma</i>
(D)	<i>Heart of Darkness</i>



**Q.21 – Q.30 Multiple Choice Question (MCQ), carry TWO mark each (for each wrong answer: – 2/3).**

<b>Q. 21</b>	<b>Match the following plays with genre or style:</b>			
	<b>i</b>	<i>Hayavadana</i>	<b>a</b>	<b>Political satire</b>
	<b>ii</b>	<i>Harvest</i>	<b>b</b>	<b>Modernist play reworking the folk</b>
	<b>iii</b>	<i>Ghashiram Kotwal</i>	<b>c</b>	<b>Theatre of the absurd</b>
	<b>iv</b>	<i>Evam Indrajit</i>	<b>d</b>	<b>Futuristic dystopia</b>
<b>(A)</b>	i-b, ii-d, iii-a, iv-c			
<b>(B)</b>	i-a, ii-c, iii-b, iv-d			
<b>(C)</b>	i-d, ii-b, iii-c, iv-a			
<b>(D)</b>	i-c, ii-d, iii-a, iv-b			



<p><b>Q. 22</b></p>	<p><i>Study the three examples below:</i></p> <p><b>i) In George Orwell’s novel <i>1984</i>, the interior ministry of the totalitarian state is called the ‘Ministry of Love’.</b></p> <p><b>ii) In the genre of horror fiction, the reader knows that the killer is hiding in the closet, but the protagonist does not.</b></p> <p><b>iii) “But Brutus says he was ambitious; And Brutus is an honourable man.” (William Shakespeare, <i>Julius Caesar</i>)</b></p> <p><i>These are instances of _____.</i></p>
<p>(A)</p>	<p>metaphor</p>
<p>(B)</p>	<p>irony</p>
<p>(C)</p>	<p>parody</p>
<p>(D)</p>	<p>synecdoche</p>

<p><b>Q. 23</b></p>	<p>An “implied reader” is a _____.</p>
<p>(A)</p>	<p>reader who participates in creating the meaning of a text</p>
<p>(B)</p>	<p>reader who anticipates authorial intention</p>
<p>(C)</p>	<p>hypothetical reader, not the actual reader, that the text addresses</p>
<p>(D)</p>	<p>reader who reads critically against the grain of the text</p>



<p><b>Q. 24</b></p>	<p><b>Read the following:</b></p> <p><b>“[...] a text is made of multiple writings, drawn from many cultures and entering into mutual relations of dialogue, parody, contestation, but there is one place where this multiplicity is focused and that place is the reader, not, as was hitherto said, the author. [...] the birth of the reader must be at the cost of the death of the Author.”</b></p> <p><b>Which theoretical school does the excerpt best represent?</b></p>
<p>(A)</p>	<p>Reader-response criticism</p>
<p>(B)</p>	<p>Formalism</p>
<p>(C)</p>	<p>Post-structuralism</p>
<p>(D)</p>	<p>New Criticism</p>

<p><b>Q. 25</b></p>	<p><b>Literary criticism considers which one of the following texts as offering the strongest support for mimetic theories of art?</b></p>
<p>(A)</p>	<p>Plato, <i>Republic</i></p>
<p>(B)</p>	<p>Longinus, <i>On Sublimity</i></p>
<p>(C)</p>	<p>Horace, <i>The Art of Poetry</i></p>
<p>(D)</p>	<p>Aristotle, <i>Poetics</i></p>



<p><b>Q. 26</b></p>	<p>The following is a passage about O. V. Vijayan’s <i>The Legends of Khasak</i>:</p> <p>The novel is set in a remote village, in the middle of the 20<sup>th</sup> century. The narrative is replete with images of the vast ecosystem of the living and the non-living, a land potent with dreams and legends.</p> <p>The analysis presented in this description is congruent with which one of the following concepts proposed by Mikhail Bakhtin?</p>
<p>(A)</p>	<p>Chronotope</p>
<p>(B)</p>	<p>Dialogism</p>
<p>(C)</p>	<p>Carnavalesque</p>
<p>(D)</p>	<p>Polyphony</p>

<p><b>Q. 27</b></p>	<p>Which one of the following did NOT happen in 1919, the year the First World War ended?</p>
<p>(A)</p>	<p>The Progressive Writers’ Association was formed in India.</p>
<p>(B)</p>	<p>The radical political activist and philosopher Rosa Luxemborg was murdered.</p>
<p>(C)</p>	<p>Rabindranath Tagore renounced his knighthood.</p>
<p>(D)</p>	<p>James Joyce’s <i>Ulysses</i> was being serialised.</p>



<b>Q. 28</b>	<p><b>Assertion P:</b> Dalit narratives tend to be read single-dimensionally as evoking the reader's pity at the protagonist's caste humiliation, or as telling the story of heroic protest against discrimination, or as a description of the protagonist's rise from misery to triumph.</p> <p><b>Assertion Q:</b> There is a tendency to keep the Other in the space of difference, as perpetually exotic.</p> <p><b>In the context of the assertions above, which one of the following statements is true?</b></p>
(A)	P and Q are contradictory assertions.
(B)	P and Q are compatible assertions.
(C)	P and Q cannot be read in relation to each other.
(D)	Q is the only explanation for P.

<b>Q. 29</b>	<p><b>Some of the recent novels of the Brazilian writer Paulo Coelho were published in multiple languages simultaneously, or immediately after the Portuguese edition.</b></p> <p><b>Which of the following is this phenomenon NOT an evidence of?</b></p>
(A)	Rebecca Walkowitz's argument that novels are often 'born translated'
(B)	The globality of marketplace for books
(C)	Paulo Coelho's expanding popularity
(D)	The 'nation' as the sole frame for understanding literature



<b>Q. 30</b>	<b>Match the authors in the first column with their respective translators in the second column.</b>			
	<b>i</b>	<b>Madhavikutty</b>	<b>a</b>	<b>A. K. Ramanujan</b>
	<b>ii</b>	<b>U. R. Ananthamurthy</b>	<b>b</b>	<b>Dilip Chitre</b>
	<b>iii</b>	<b>Indira Goswami</b>	<b>c</b>	<b>Kamala Das</b>
	<b>iv</b>	<b>Namdeo Dhasal</b>	<b>d</b>	<b>Aruni Kashyap</b>
(A)	i-d, ii-c, iii-b, iv-a			
(B)	i-c, ii-b, iii-d, iv-a			
(C)	i-c, ii-a, iii-d, iv-b			
(D)	i-b, ii-a, iii-d, iv-c			



Q.31 – Q.40 Multiple Select Question (MSQ), carry TWO mark each (no negative marks).

Q. 31	Which of the following is/are true about Gilles Deleuze and Felix Guattari's conception of 'minor literature'?
(A)	The discussion focuses on the writing of Franz Kafka.
(B)	Minor literature is literature that a minority produces in a major language.
(C)	Minor literature is a form of popular literature.
(D)	Minor literature is literature in a minor language.



<p><b>Q. 32</b></p>	<p><b>Quote P:</b>  <b>“O wild West Wind, thou breath of Autumn's being,          Thou, from whose unseen presence the leaves dead          Are driven, like ghosts from an enchanter fleeing,</b></p> <p><b>Yellow, and black, and pale, and hectic red,          Pestilence-stricken multitudes: O thou,          Who chariotest to their dark wintry bed          [...]</b>”</p> <p><b>Quote Q:</b>  <b>“O golden-tongued Romance with serene lute!          Fair plumed Siren! Queen of far away!”</b></p> <p><b>Which of the following is/are correct?</b></p>
<p>(A)</p>	<p>Both quotes are examples of apostrophe.</p>
<p>(B)</p>	<p>Both quotes use alliteration.</p>
<p>(C)</p>	<p>Both quotes are examples of aporia.</p>
<p>(D)</p>	<p>Both quotes are examples of personification.</p>



<p><b>Q. 33</b></p>	<p><b>Prolepsis is the representation or assumption in the present, of a future act or development.</b></p> <p><b>Which of the following is/are instance/s of prolepsis?</b></p>
<p>(A)</p>	<p>“Six decades later she would describe how at the age of thirteen she had written her way through a whole history of literature.” Ian McEwan, <i>Atonement</i>.</p>
<p>(B)</p>	<p>“Horatio, I am dead.” William Shakespeare, <i>Hamlet</i>.</p>
<p>(C)</p>	<p>“In my younger and more vulnerable years my father gave me some advice that I’ve been turning over in my head ever since.” F. Scott Fitzgerald, <i>The Great Gatsby</i>.</p>
<p>(D)</p>	<p>“Many years later, as he faced the firing squad, Colonel Aureliano Buendía was to remember that distant afternoon when his father took him to discover ice.” Gabriel García Márquez, <i>One Hundred Years of Solitude</i>.</p>

<p><b>Q. 34</b></p>	<p><b>Gayatri Chakravorty Spivak’s essay “Can the Subaltern Speak?” proposes which of the following?</b></p>
<p>(A)</p>	<p>The voice of the subaltern is appropriated by ‘intellectuals’ desiring to speak for the subaltern.</p>
<p>(B)</p>	<p>It is easy to confuse writing about the subaltern with the subaltern speaking for herself.</p>
<p>(C)</p>	<p>All women are subaltern and therefore cannot truly speak.</p>
<p>(D)</p>	<p>The ‘intellectuals’ speaking for the subaltern and the subaltern speaking for herself can be equivalent.</p>



<b>Q. 35</b>	<b>Which of the following is/are example/s of ‘metafiction’?</b>
(A)	Each chapter in a novel is narrated by a different character.
(B)	The reader is a character in the novel who interrupts the story because he realises that he is reading an incomplete text.
(C)	The narrator of the novel travels into the wild and encounters a man who embodies the horrors of colonial power. The latter then proceeds to tell his story.
(D)	A character in a novel encounters a shabbily dressed man. Soon, this man lets us, the readers, know that he is the author of the novel and is contemplating the future of this character.

<b>Q. 36</b>	<b>Choose one or more options from below.</b> <b>In contrast to traditional Historicism, New Historicism _____.</b>
(A)	rejects the idea that history is an objective narrative of events unfolding in linear time
(B)	does not make strict distinctions between literary and non-literary texts
(C)	takes a particular interest in the textualisation of the material world
(D)	takes history only to be a background and context for understanding literary texts



Q. 37	<p><b>“The feminist insistence that ‘the personal is political’ has had profound effects on other genres. Feminist academics in several disciplines now insist that the subjective element must not be left out of the practice of research methods, such as the interview, or of theories of knowledge production (Skeggs 1995; Maynard and Purvis 1994; Reinhartz 1992).”</b></p> <p><b>From the passage above, which of the following can be correctly concluded?</b></p>
(A)	The passage argues that interviews and theories of knowledge production are not examples of research methods.
(B)	‘The personal is political’ is a feminist argument.
(C)	Skeggs, Maynard, Purvis, and Reinhartz are names of feminist scholars.
(D)	The passage argues that the subjective can legitimately be part of research methods.



<p><b>Q. 38</b></p>	<p>“ARE YOU DARK? OR VERY LIGHT?” Revelation came.          “You mean—like plain or milk chocolate?”          Her assent was clinical, crushing in its light          Impersonality. Rapidly, wave-length adjusted,          I chose. “West African sepia”—and as afterthought,          “Down in my passport.” Silence for spectroscopic          Flight of fancy, till truthfulness clanged her accent          Hard on the mouthpiece. “WHAT’S THAT?” conceding          “DON’T KNOW WHAT THAT IS.” “Like brunette.”          “THAT’S DARK, ISN’T IT?” “Not altogether.          Facially, I am brunette, but, madam, you should see          The rest of me. Palm of my hand, soles of my feet          Are a peroxide blond. Friction, caused—          Foolishly, madam—by sitting down, has turned          My bottom raven black—One moment, madam!”—sensing          Her receiver rearing on the thunderclap          About my ears—“Madam,” I pleaded, “wouldn’t you rather          See for yourself?”</p> <p>In Wole Soyinka’s “Telephone Conversation”, the man seeking to rent a room responds to the white landlady’s racism by _____.</p>
<p>(A)</p>	<p>describing black as a spectrum as opposed to a single colour</p>
<p>(B)</p>	<p>being the subservient Black man, who concedes to her definition of race</p>
<p>(C)</p>	<p>locating race squarely in her ways of seeing</p>
<p>(D)</p>	<p>fragmenting the racialised body</p>



Q. 39	In Arthur Conan Doyle's writings featuring Sherlock Holmes, as is the case with much of 19 <sup>th</sup> century British fiction, colonialism appears as objects, events, animals, places, fears and desires. Which of the following support/s this claim?
(A)	Opium dens in London, frequented by Holmes
(B)	The war in which Watson served as a doctor
(C)	The hound in <i>The Hound of the Baskervilles</i>
(D)	The pet animals in "The Adventure of the Speckled Band"



<p><b>Q. 40</b></p>	<p><b>“My Papa’s Waltz” by Theodore Roethke</b></p> <p><b>The whiskey on your breath Could make a small boy dizzy; But I hung on like death: Such waltzing was not easy.</b></p> <p><b>We romped until the pans Slid from the kitchen shelf; My mother’s countenance Could not unfrown itself.</b></p> <p><b>The hand that held my wrist Was battered on one knuckle; At every step you missed My right ear scraped a buckle.</b></p> <p><b>You beat time on my head With a palm caked hard by dirt, Then waltzed me off to bed Still clinging to your shirt.</b></p> <p><b>Which of the following can be observed about this poem?</b></p>
<p>(A)</p>	<p>The form of the poem is that of the Petrarchan sonnet.</p>
<p>(B)</p>	<p>There is a simile in the first stanza.</p>
<p>(C)</p>	<p>Images in the last two stanzas suggest that the father is a working-class man.</p>
<p>(D)</p>	<p>The poem is in rhyming couplets.</p>

**END OF THE QUESTION PAPER**

## Graduate Aptitude Test in Engineering (GATE 2021)

## Subject/Paper: Humanities and Social Sciences (XH) / English (XH-C2)

Q. No.	Session	Question Type MCQ/MSQ/NAT	Section Name	Answer Key/Range	Marks	Negative Marks
1	7	MCQ	GA	D	1	1/3
2	7	MCQ	GA	D	1	1/3
3	7	MCQ	GA	D	1	1/3
4	7	MCQ	GA	D	1	1/3
5	7	MCQ	GA	C	1	1/3
6	7	MCQ	GA	C	2	2/3
7	7	MCQ	GA	A	2	2/3
8	7	MCQ	GA	C	2	2/3
9	7	MCQ	GA	C	2	2/3
10	7	MCQ	GA	D	2	2/3
1	7	MCQ	XH-B1	C	1	1/3
2	7	MCQ	XH-B1	C	1	1/3
3	7	MCQ	XH-B1	C	1	1/3
4	7	MCQ	XH-B1	D	1	1/3
5	7	MCQ	XH-B1	C	1	1/3
6	7	MCQ	XH-B1	A	2	2/3
7	7	MCQ	XH-B1	C	2	2/3
8	7	MCQ	XH-B1	C	2	2/3
9	7	MCQ	XH-B1	D	2	2/3
10	7	MCQ	XH-B1	B	2	2/3
11	7	MSQ	XH-B1	C; D	2	0
12	7	MSQ	XH-B1	B; C	2	0

**GATE 2021 Answer Key- Humanities and Social Sciences (XH) / English (XH-C2)**

<b>Q. No.</b>	<b>Session</b>	<b>Question Type MCQ/MSQ/NAT</b>	<b>Section Name</b>	<b>Answer Key/Range</b>	<b>Marks</b>	<b>Negative Marks</b>
13	7	MSQ	XH-B1	<b>A; B</b>	2	0
14	7	MSQ	XH-B1	<b>A; B</b>	2	0
15	7	MSQ	XH-B1	<b>A; C; D</b>	2	0
1	7	MCQ	XH-C2	<b>C</b>	1	1/3
2	7	MCQ	XH-C2	<b>C</b>	1	1/3
3	7	MCQ	XH-C2	<b>A</b>	1	1/3
4	7	MCQ	XH-C2	<b>C</b>	1	1/3
5	7	MCQ	XH-C2	<b>B</b>	1	1/3
6	7	MCQ	XH-C2	<b>A</b>	1	1/3
7	7	MCQ	XH-C2	<b>B</b>	1	1/3
8	7	MCQ	XH-C2	<b>D</b>	1	1/3
9	7	MCQ	XH-C2	<b>A</b>	1	1/3
10	7	MCQ	XH-C2	<b>A</b>	1	1/3
11	7	MCQ	XH-C2	<b>MTA</b>	1	1/3
12	7	MCQ	XH-C2	<b>A</b>	1	1/3
13	7	MSQ	XH-C2	<b>A; B; C</b>	1	0
14	7	MSQ	XH-C2	<b>A; B</b>	1	0
15	7	MSQ	XH-C2	<b>B</b>	1	0
16	7	MSQ	XH-C2	<b>B; C; D</b>	1	0
17	7	MSQ	XH-C2	<b>A; B; D</b>	1	0
18	7	MSQ	XH-C2	<b>A; B; C</b>	1	0
19	7	MSQ	XH-C2	<b>A; C</b>	1	0
20	7	MSQ	XH-C2	<b>B; D</b>	1	0
21	7	MCQ	XH-C2	<b>A</b>	2	2/3
22	7	MCQ	XH-C2	<b>B</b>	2	2/3
23	7	MCQ	XH-C2	<b>C</b>	2	2/3
24	7	MCQ	XH-C2	<b>C</b>	2	2/3

**GATE 2021 Answer Key- Humanities and Social Sciences (XH) / English (XH-C2)**

<b>Q. No.</b>	<b>Session</b>	<b>Question Type MCQ/MSQ/NAT</b>	<b>Section Name</b>	<b>Answer Key/Range</b>	<b>Marks</b>	<b>Negative Marks</b>
25	7	MCQ	XH-C2	<b>D</b>	2	2/3
26	7	MCQ	XH-C2	<b>A</b>	2	2/3
27	7	MCQ	XH-C2	<b>A</b>	2	2/3
28	7	MCQ	XH-C2	<b>B</b>	2	2/3
29	7	MCQ	XH-C2	<b>D</b>	2	2/3
30	7	MCQ	XH-C2	<b>C</b>	2	2/3
31	7	MSQ	XH-C2	<b>A; B</b>	2	0
32	7	MSQ	XH-C2	<b>A; D</b>	2	0
33	7	MSQ	XH-C2	<b>A; B; D</b>	2	0
34	7	MSQ	XH-C2	<b>A; B</b>	2	0
35	7	MSQ	XH-C2	<b>B; D</b>	2	0
36	7	MSQ	XH-C2	<b>A; B; C</b>	2	0
37	7	MSQ	XH-C2	<b>B; C; D</b>	2	0
38	7	MSQ	XH-C2	<b>A; C; D</b>	2	0
39	7	MSQ	XH-C2	<b>A; B; D</b>	2	0
40	7	MSQ	XH-C2	<b>B; C</b>	2	0
<b>MTA means Marks to All</b>						